

# LABEL DISPENSER

MODEL: SH-404

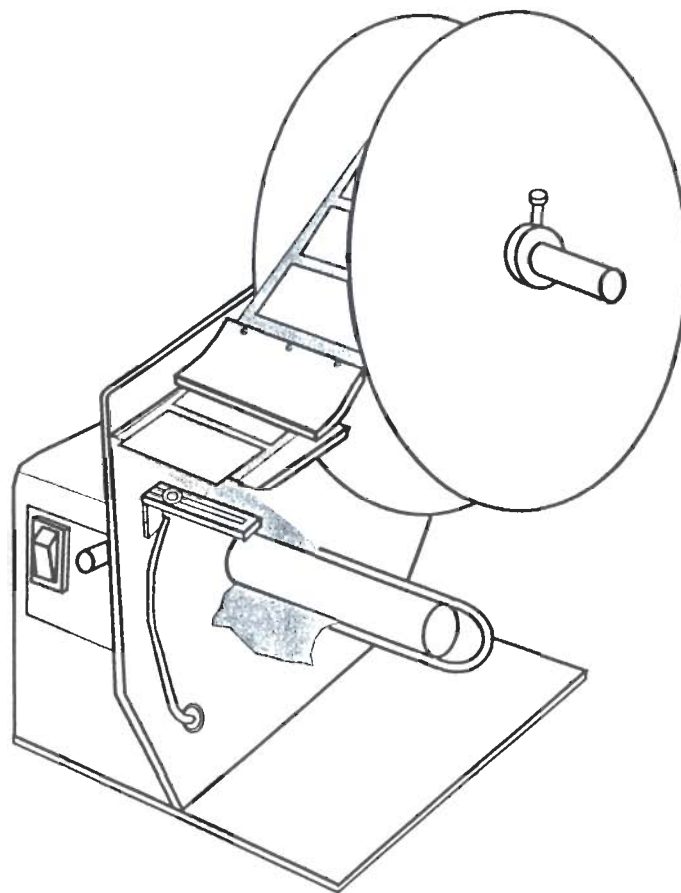

## USER MANUAL

OPERATION, MAINTENANCE AND TROUBLESHOOTING

# EXTERNAL VIEW

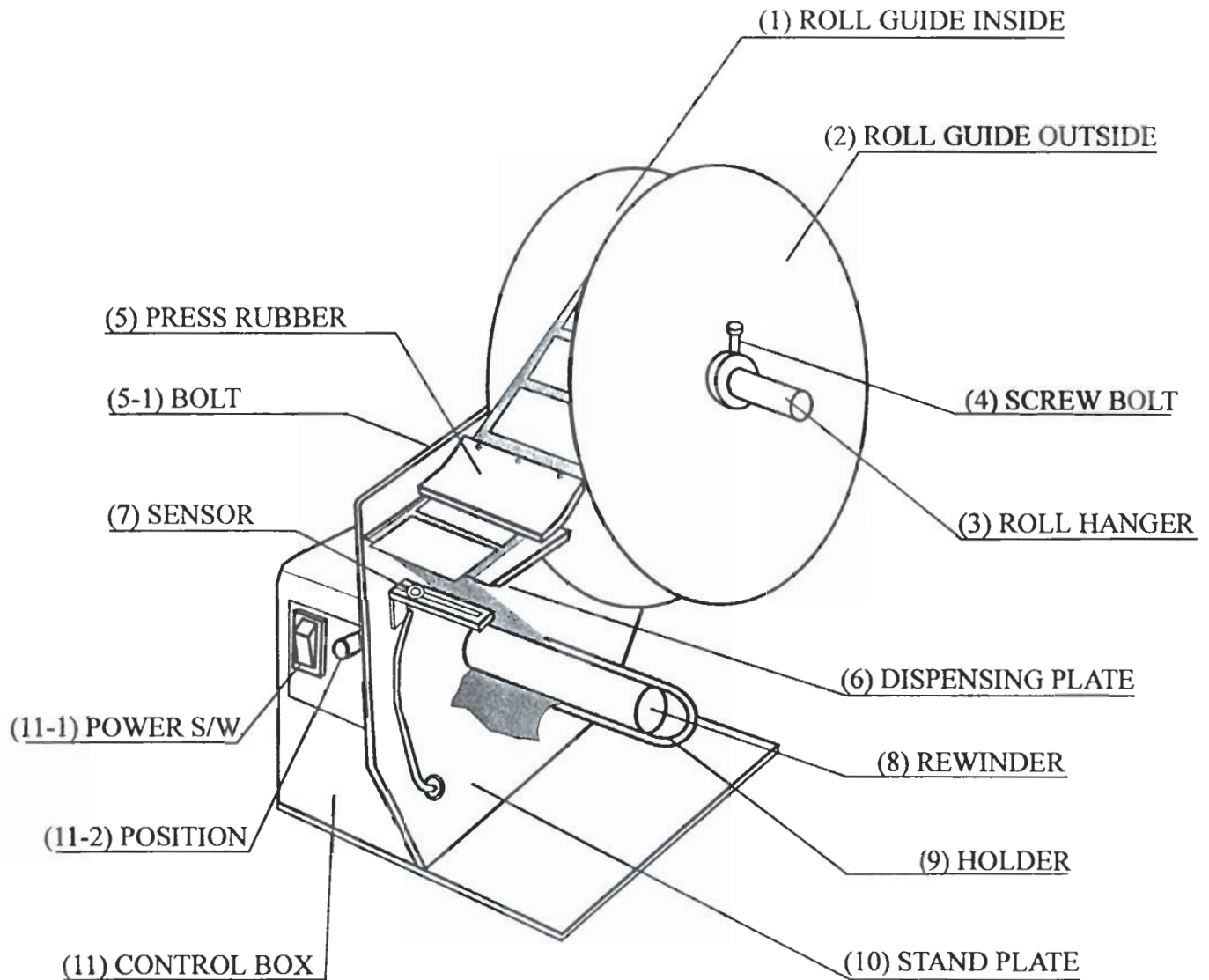

## SPECIFICATION

- LABEL SIZE - MAX: 150(W)×200(H)MM  
MIN: 10(W)×15(H)MM
- LABEL ROLL MAX:Φ230MM
- SPEED - 5M/MIN
- POWER - 100,110,120,220,240VAC
- DISMENSION - 280(W)×350(L)×275(H)MM
- WEIGHT - 6KGS

# LABEL SETTING PROCEDURE

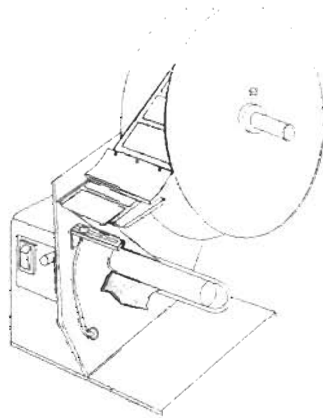

1. LOOSEN THUMB SCREW AND SLIDE OUTSIDE ROLL GUIDE(2) OUT OF ROLL HANGER(3).
2. PUSH LABEL ROLL INTO ROLL HANGER(3). MAKE SURE LABEL IS ON TOP.
3. THREAD LEADING END OF LABEL BETWEEN PRESS RUBBER(5) AND DISPENSING PLATE(6).
4. CONTINUE TO THREAD LABEL AS SHOWN IN PICTURE. GRIP LEADING END INTO THE GROOVE IN REWINDER(8).
5. THE SETTING OF POSITION KNOB SHOULD BE INITIALLY SET AT 1.
6. TURN POWER SWITCH "ON".
7. ADJUST SETTING OF POSITION KNOB UNTIL THE DESIRED LENGTH OF LABEL FEED IS ACHIEVE.

## NOTE:

- MOTOR WILL OVERHEAT IF RUN FOR A PROLONG PERIOD OF TIME WITHOUT INTERRUPTION.  
MOTOR OVERHEAT PROTECTION WILL AUTOMATICALLY SHUT OFF THE MOTOR TO ALLOW IT TO COOL DOWN.  
ONCE THE MOTOR COOL DOWN, IT WILL BE READY TO RUN AGAIN.
- PRESS RUBBER(5) CAN BE ADJUSTED TO ACHIEVED DESIRED LABEL TENSION.

# NOTICE

·DISCONNECT FROM POWER SUPPLY WHEN CARRYING OUT ANY MAINTENANCE.

## CLEAN

1. DO NOT-SPRAY OR SPLASH FLUIDS OVER MACHINE.
2. DO NOT-REMOVE OR ADJUST THE FACTORY PRESET PEEL PLATE.
3. DO-KEEP ALL SURFACES CLEAN.

SPECIALLY CLEAN UNDER THE PRESS POLY-URETHAN.

## LABEL

4. IT SHOULD HAVE THE GAP BETWEEN THE LABELS.
5. IT SHOULD NOT HAVE CUT LINE IN BACKING PAPER.
6. LABEL ROLL SHOULD BE LESS THEN  $\Phi$ 230MM.  
MAXIMUM OF LABEL SIZE IS 150(W) X 200(H)MM  
MINIMUM OF LABEL SIZE IS 10(W) X 15(H)MM
8. SENSOR IS LOCATED BY LOOSEN TWO BOLTS.  
IF LABEL IS NO FORMAL, THE LONGEST IS A DATUM POINT.
9. WHEN LABEL IS EXCHANGED BY OTHER SIZE, THE POSITION VOLUME SHOULD BE START FROM "0".
10. USE PROPER VOLTAGE WHICH IS MARKED IN THE LABEL OF MACHINE.
11. THE FUSE SHOULD BE 3A.

# Trouble shooting

TROUBLE	SHOOTING
Machine does not start	<ul style="list-style-type: none"> <li>▪ Check if power cord is connected to the machine and power outlet.</li> <li>▪ Check if the fuse is blown. Remove fuse from back panel, replace if necessary.</li> </ul>
Label does not advance or label does advance continually	<ul style="list-style-type: none"> <li>▪ Referring to the threading diagram, check if the label is properly threaded into the machine.</li> <li>▪ Check if sensor (9) is far from dispensing plate and it is sensing always the dispensing plate(7).</li> </ul>
Label does not put on exact position	<ul style="list-style-type: none"> <li>▪ Check if label is setting correctly on label hanger.</li> </ul>
Back paper is not rewinding	<ul style="list-style-type: none"> <li>▪ Check if the back paper comes out.</li> <li>▪ Check if back paper is fixed into the pin of rewinder roller(10).</li> </ul>
The others	<ul style="list-style-type: none"> <li>▪ Ask to distributor or manufacturer.</li> </ul>

# PART LIST

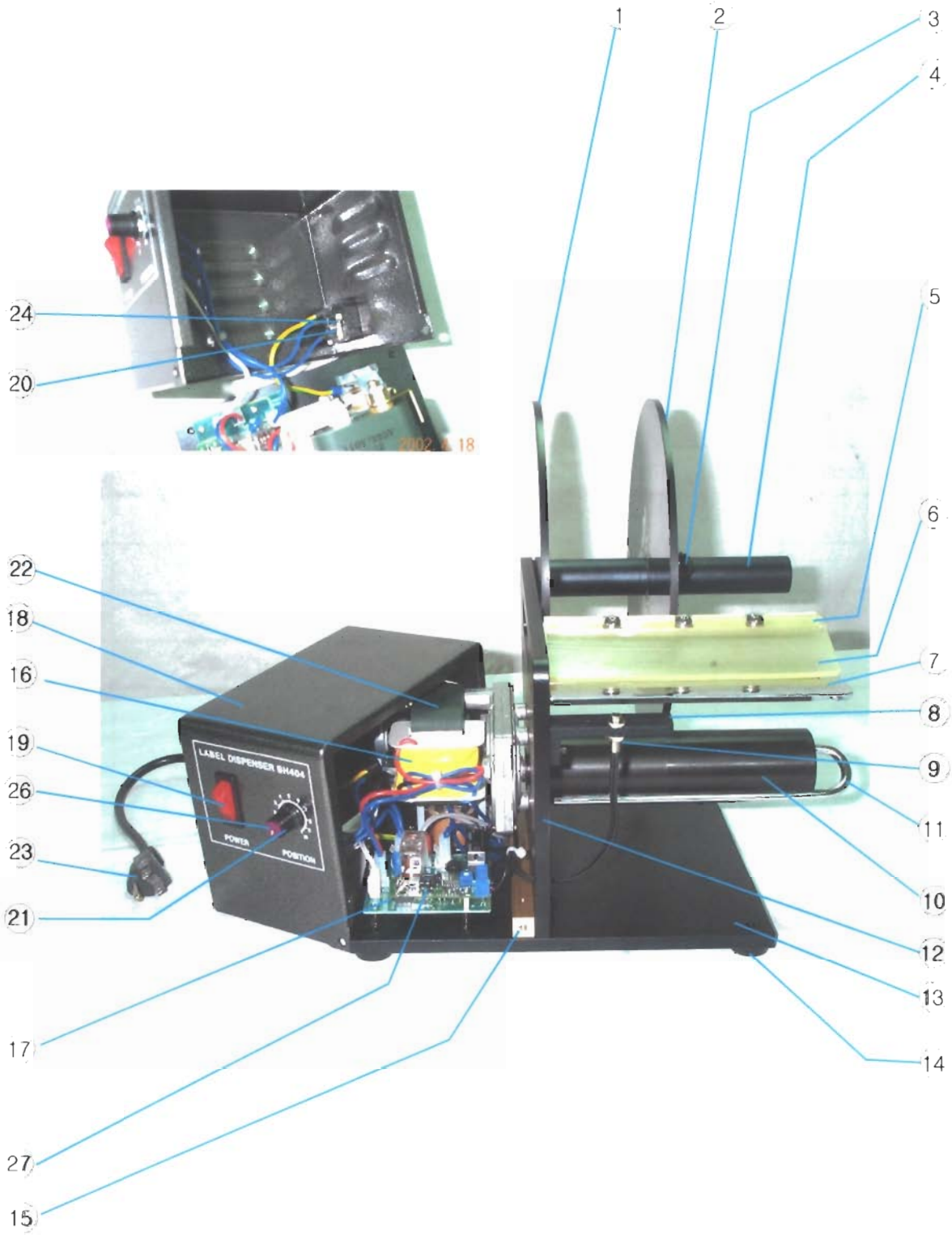

## PARTS LIST FOR DISPENSER MODEL SH-404

Apr. 2002

PART NO.	PART NAME	MODEL NO.	REMARK
1	ROLL GUIDE INSIDE		φ230mm
2	ROLL GUIDE OUTSIDE		
3	SCREW BOLT		5×20MM
4	ROLL HANGER		
5	SHAFT		150mm
6	PRESS POLY-URETHAN		
7	DISPENSING PLATE		150 × 80mm
8	SENSOR BRACKET		
9	SENSOR	BR-6MPT	
10	REWINDER		150mm
11	U-PIN HOLDER		
12	STAND PLATE(AL)		
13	BASE PLATE(AL)		
14	BOTTOM RUBBER		
15	STAND PLATE BAR		
16	TRANSFORMER	AC110V/60Hz, AC12V, 300MA	
17	P.C. BOARD		
18	CONTROL BOX		
19	POWER S/W		30×11MM
20	FUSE	250V, 3A	
21	POSITION VOLUME	500K	
22	MOTOR	KGB-086-6130BF	
23	AC IN CABLE	KKP-4819R/KKS-16A	
24	INLET	RF-2004	
26	KNOB		
27	SENSOR PCB	SB-11	

# TRANSFORMER

