

TACH-IT[®]

Operations Manual for Tach-It Mini-Con Wipe On Labeller with Conveyor.



Ben Clements and Sons, Inc. / Clements Industries, Inc.

50 Ruta Court, South Hackensack, New Jersey 07606 USA

Tel: 201-440-5500, Toll Free: 800-222-5540, Fax: 201-440-1455

Email: sales@tach-it.com, Website: www.tach-it.com

Clements Industries Japan, Clements Industries, Inc. Korea

Tach-It and Twisters are registered, copyrighted or trademarks of Clements Industries, Inc.

Copyright Ben Clements and Sons, Inc. and Clements Industries, Inc. August 2008

TABLE OF CONTENTS:

Section #1 Caution:	Page 3
Section #2 Specifications:	Page 3
Section #3 Set Up of the Machine:	Page 4
Section #4 Loading of the Labels:	Page 5
Section #5 Operation of the Touch Panel Controller:	Page 7
Section #6 Operation of the Tach-It Mini-Con Labeler:	Page 9
Section #7 Adjustment to the Sensitivity of the Stop Sensor:	Page 10
Section #8 Trouble Shooting:	Page 10
Section #9 Parts Identification:	Page 12

SECTION #1 CAUTION:

- Before operating the machine, read the complete operator manual.
- Never have the power on this machine plugged into the power supply when any of the covers of the machine have been removed.
- Install and operate this machine only on a flat, level and dry surface.
- Use only the manufacturers specified electrical power input with this machine.
- Always keep hands, clothing, jewelry, and hair away from all moving parts of this machine including the Conveyor belt.
- Do not operate this machine with any of the protective covers removed or opened.
- Do not operate this machine without the pressure sensitive labels in their proper feeding position.
- Keep this machine clean and dry at all times.
- Do not use the machine in an area where flammables, explosive materials or fumes are present.
- Any modification to the machine makes the warranty null and void.
- Service on this machine should only be performed by factory trained authorized service personnel.
- Never use this machine for other than its intended applications. Use of the machine on unintended applications can cause harm to the operator, the machine, and the product. Please contact the manufacturer if there are any questions to whether this machine can be used for a particular application.

SECTION #2 SPECIFICATIONS:

Electric Power:	115 VAC
Machine Length:	57" (145cm) (includes stainless stations)
Machine Width:	18" (47cm)
Machine Height:	36" (93cm)
Label Size Maximum:	5.1" (130mm) Wide x 11" (280mm) Long
Label Size Minimum:	.40" (10mm) Wide x .75" (20mm) Long
Label Speed Maximum:	59.1 Ft (18 meters) per minute
Label Speed Minimum:	46 Ft (14 meters) per minute
Conveyor Width:	10.6" (270mm)
Conveyor Length:	39.4" (1 meter)

SECTION #3 SET UP OF THE MACHINE:

Please Identify, confirm and check each of the below main components of the Mini-Con Labeller.

- Main Label Head
- Controller
- Conveyor

Figure #1

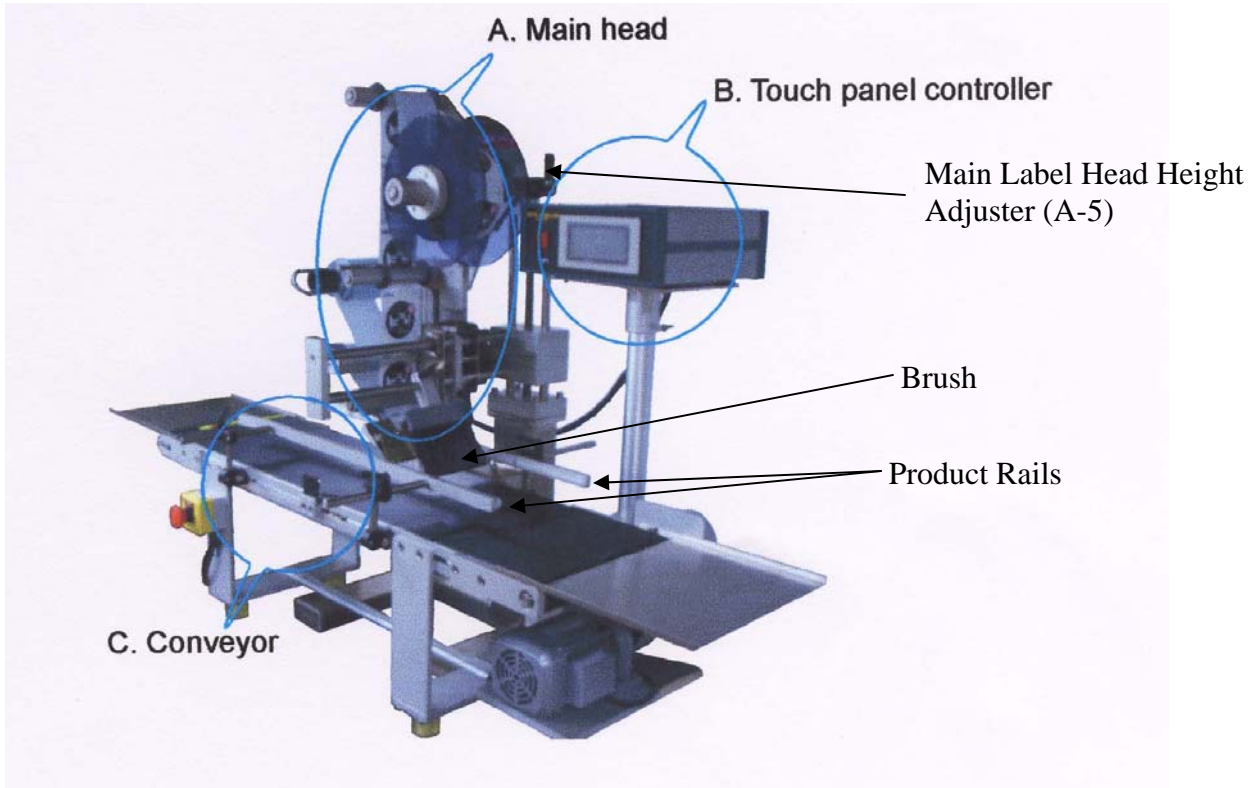

- 1) Attach the Stainless Stations to the ends of the Conveyor (C-3) if desired see Figure #1 above.
- 2) To set up the machine, place the item to be labeled onto the Conveyor Belt and put it in the position relevant to the label Dispensing Plate (A-6) where the label is to be applied on the product. The Dispensing Plate (A-6) can be moved across the width of the Conveyor by loosening the Black Knobs (A-4) and sliding the entire Main Label Head to the desired position relevant to the Conveyor and then tightening the Black Knobs (A-4).
- 3) Locate the 2 adjustable Product Rails that run along the length of the Conveyor. These Product Rails are adjustable in both height and location. Locate the Black Knobs which hold the Product Rails in place and move them either into or away from the product so that the product is contained and can not move either left or right, but not so that the Product Rails are tight enough to impede the product moving along the Conveyor Belt.
- 4) Locate The Main Label Head Height Adjuster (A-5) which is located on the back of the machine behind the Main Label Head. This screw adjustment is used to put the Label Dispensing Plate at the correct height relative to the product to be labeled. If at this point it is below the height of the product, turn the handle and raise the Main Label Head so that it is about 1" above the product. Put the product directly below the Label Dispensing Plate (A-6) and slowly turn the Main label Head Height Adjuster (A-5) until it is from 0.5mm to 1mm above the product. See Figure 2 on the following page for details. After the above is completed, move the package to the right of the Main Label Head and adjust the brush so that it lightly touches the top of the package.
- 5) The machine is now ready for the product and the next step will instruct on how to load the pressure sensitive labels onto the machine.

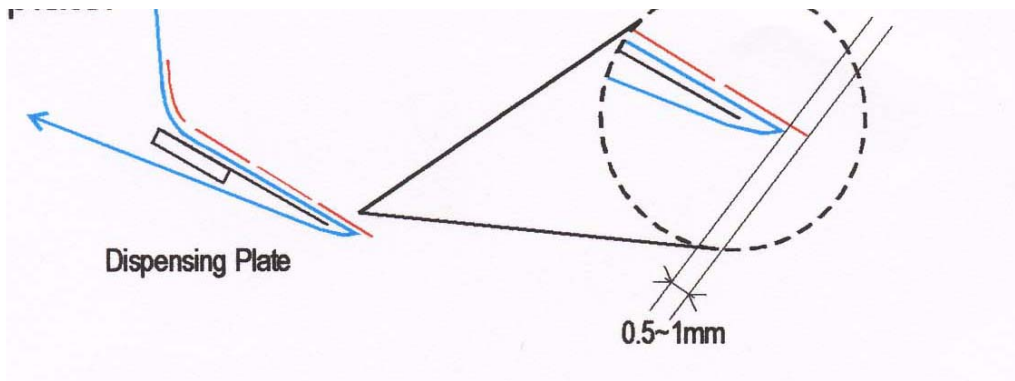

Figure #2

SECTION #4 LOADING OF LABELS:

Note: In order to ensure consistent label placement unto the product, during the Label Loading process, the labels must be straight and the same distant from the body of the Main Label Head throughout the entire Label Feeding Path. Many of the Rollers that are along the Label Feed Path have Spring Collars which should be used to assist in keeping the labels straight. See Figure 3

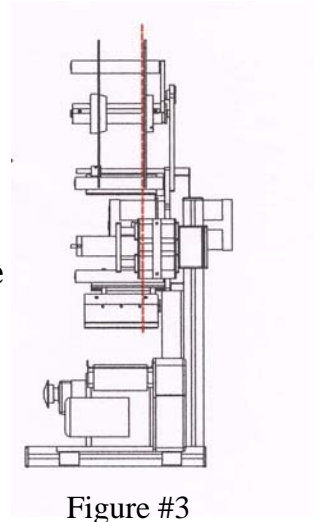

Figure #3

- 1) Locate the Label-Hanger Inside (A-1-1) and the Label Hanger Outside (A-1-2) The difference between the 2 is that the Label Hanger Inside (A-1-1) uses a Set Screw to lock it into place while the Label Hanger Outside (A-1-2) uses an adjustable Black Knob.
- 2) Keeping in mind the note above and Figure #4, secure the label Hanger Inside onto the shaft and tighten with an allen screw. Put the roll of labels onto the shaft so that the labels feed off the bottom of the roll as per Figure 4 and then secure the roll with the Label Hanger Outside (A-1-2).

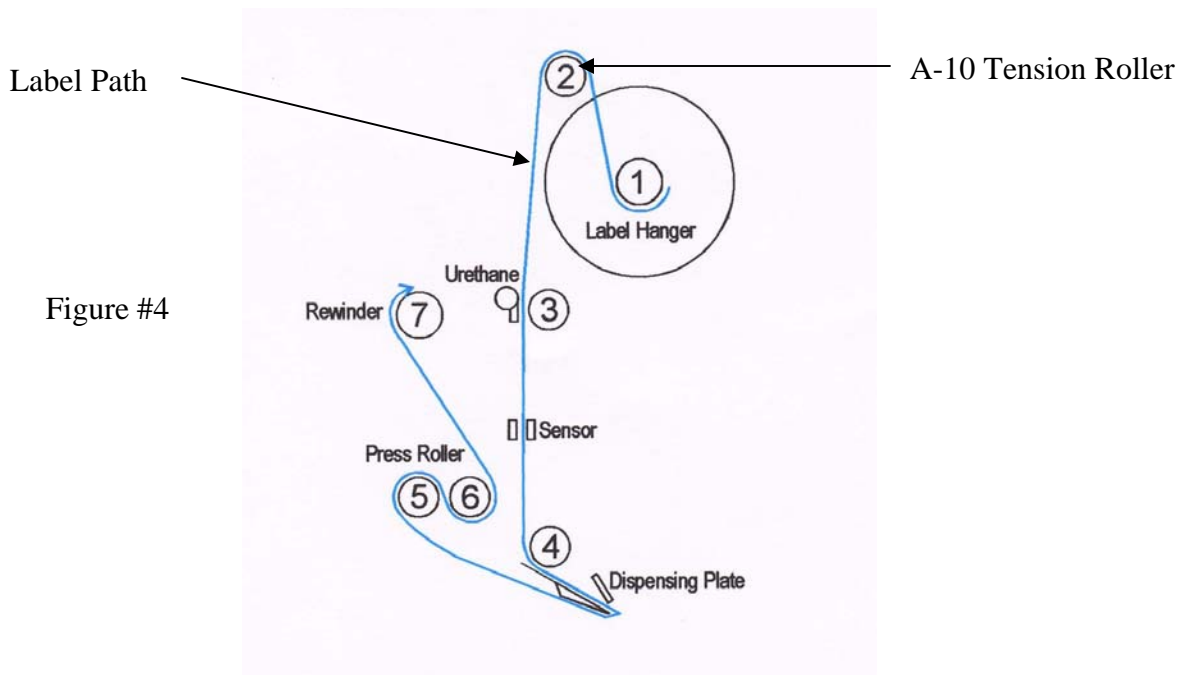
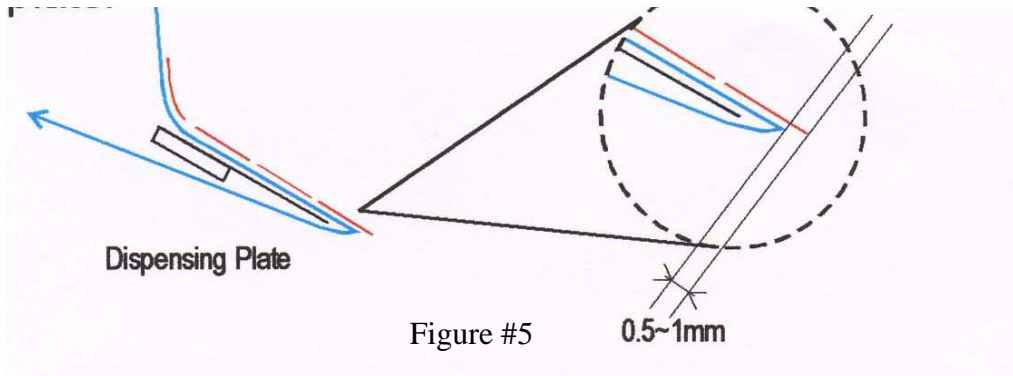

Figure #4

SECTION #4 LOADING OF LABELS CONTINUED:

- 3) Verifying that the labels are feeding off the bottom of the roll, take the leading edge of the labels and bring it over A-10 Tension Roller and then in between Roller #3 and the Urethane Wiper. There is a thumb screw that will allow the Urethane Wiper to swivel out of the way, but once the labels are past this point, replace the Urethane Wiper to its original position.
- 4) Continue feeding the leading edge of the labels to the Stop Sensor (A-3) and in between the 2 halves of the sensor. This sensor will read the gap in between the labels and determine when the feed portion of the cycle should stop.
- 5) Feed the leading edge of the labels behind roller #4 on Figure #4 and then under the Urethane Wiper and around the Dispensing Plate A-6. At this point pull off about 18 inches of the labels from the roll and feed it around the Dispensing Plate so that 0.5mm to 1mm of a label is beyond the edge of the Dispensing Plate per Figure 5.



- 6) Making sure that the Black Handle located between the Press Rollers #5 and #6 on Figure #4, is in the open position, bring the leading edge of the labels up and over the purple neoprene roller #5 into the space between rollers #5 and #6 and then under roller #6.
- 7) Continue feeding the labels around #7 as per Figure #4 and then using the U-Clip secure the labels to the Re-winder (A-9).
- 8) At this point, locate the Stop Sensor (A-3) and note that the Stop Sensor is mounted to a rail which allows for the height of the Stop Sensor to be Adjusted. Loosening the screw, adjust the height of the Stop Sensor so that the gap in the label is located in the middle of the Stop Sensor per Figure #6.
- 9) At this point, put the Black Handle located between Rollers #5 and #6 to the closed position.
- 10) The machine is now fed and ready for use.

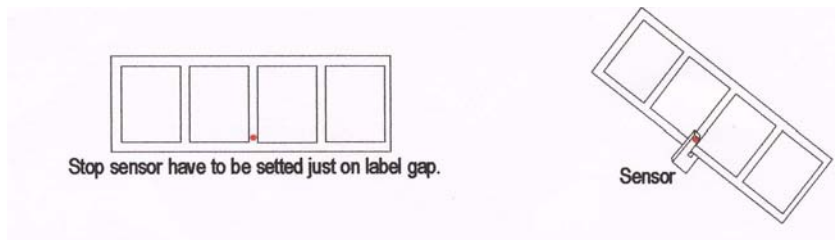

Figure #6

SECTION #5 OPERATION OF THE TOUCH PANEL CONTROLLER:

The Touch Panel Controller (B) for the Tach-It Mini-Con allows for full control of all functions of the labeller. Please note that if at any time the screen of the Touch Panel Controller turns Red, there has been an error with the labeller and it must be resolved prior to resuming work. Easy to use, the Touch Screen Controller requires only a finger to work or change any settings. Simply touch the desired box to set up the machine and use the arrow located next to the screen name to return to the previous screen. See Figure #7.

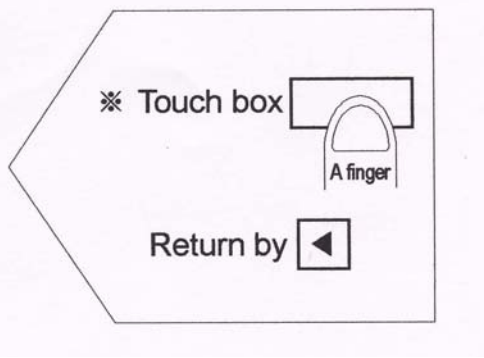

Figure #7

Home Screen: The Home Screen is what is shown when the labeller is first turned on, or when operating the machine. Through the Home Screen, you can make the necessary settings with the labeller for your specific application. Figure #8 Shows the Home Screen and a description of each of the functions is as follows:

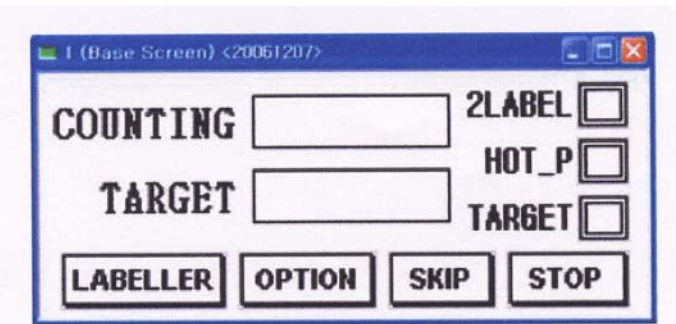

Figure #8

- Counting—Shows the # of Units that have been Labeled
- Target—If using the Target Counter Function, it shows the number of desired products to be labeled.
- 2 Label—If highlighted it shows that you are set up to put 2 labels to each product put through the machine.
- Hot_P—If highlighted it shows that the machine has an optional Hot Stamp Printer installed and that the Touch Panel Controller has been set to work with the Hot Stamp Printer.
- Target—If highlighted this shows that the Target Counter Feature is enabled.
- Labeller—This leads to a sub menu that allows for control of the Start Delay, 2 Label Delay and Motor Speed.
- Option—This leads to a sub menu that allows for the enabling and disabling of the Hot Printer, Target Counter, Conveyor Mode and 1 or 2 label mode.
- Skip—This is a function not used in the Mini-Con labeller.
- Stop—This switches between the Stop and Run mode of the labeller.

Labeller Sub-Menu: The Labeller Sub Menu allows for control of the Start Delay, 2 Label Delay and the Motor Speed. Please note that the Start Delay, the 2 Label Delay and the Motor Speed will affect the location of the label onto the product. The Start Delay is the amount of time the labeller delays from then the product is sensed by the Start Sensor (A-7) to when the label is applied. The 2 Label Delay is used if you have enabled the 2 Label function on the Option Screen (explained next page) and you have 2 labels on 1 web and this sets the delay between the 1st label and the 2nd label. The Motor Speed is the speed of the conveyor. The Start Delay, 2 Label Delay (if enabled) and the Motor Speed work in combination to ensure consistent and proper label placement. Please note that some trial and error with these settings will be required during initial set up to get proper label placement. Please see Figure #9 on the next page.

SECTION #5 OPERATION OF THE TOUCH PANEL CONTROLLER CONTINUED:



Figure #9

Using the Labeller Sub Menu:

- 1) From the Home Screen touch where it says Labeller and Figure #9 will appear.
- 2) To change the value of either the Start Delay or 2 Label Delay, touch the box which will be showing the present set value. A Numeric Keyboard will be displayed. Input the new desired value and hit the Enter Key in the lower right hand corner of the display to save the new value and to return to the Labeller Sub Menu Screen.
- 3) To change the value of the Motor Speed touch the box below Motor Speed which will be displaying the present set value. Another screen will come up as shown in Figure #10 below. This screen will show you the present value. To Change this, touch the box next to Setting Value and a Numeric Keyboard will be displayed. Input the new desired value and hit the Enter Key in the lower right hand corner of the display to save the new value and to return to the Motor Speed Screen. The Present Value and the Setting Value will now be the same. At this time you can press test to view the new speed. To return to the Labeller Sub Menu hit the arrow to the left of Motor Speed in the upper left hand corner.

Please note that the Start Delay and the Motor Speed will determine the placement of the label onto the product. This will require some trial and error to get it perfect. Once set, the label placement will be consistent. Suggestion: Do not immediately try to increase the Motor Speed believing it will increase production. This is incorrect and will only cause variations in label placement.



Figure #10

Using the Option Sub Menu:

- 1) From the Home Screen touch the Options Box and it will bring you to the Option Sub Menu.
- 2) To use the Option Sub Menu, simply touch the box next to the desired Option that is to be turned on or off. Example, to turn on the Target Counter, touch the On box to the right of the word Target. If you desire 2 Label operation, touch the 2 Label Button at the bottom right of the screen. To change to 1 Label, simply touch the 1 Label box.
- 3) See Figure #11 for a view of the Option Sub Menu.

SECTION #5 OPERATION OF THE TOUCH PANEL CONTROLLER CONTINUED:



Figure #11

To Set the Target Counter:

- 1) To set the Target Counter, first turn the option on by going to the Option Sub Menu per the previous instructions and touching the On box.
- 2) From the Home Screen, touch the box next to the word Target and an Numeric Keyboard will be displayed. Input the desired number of packages to be labeled and touch the Enter button on the bottom right of the Numeric Keyboard.
- 3) Begin to label the packages. When the pre-set Target count is completed, the screen on the Touch Panel Controller will turn Red and no more packages will be labeled.

SECTION #6 OPERATION OF THE TACH-IT MINI-CON LABELER:

- 1) Place the Mini-Con Labeller on a flat dry work surface near the proper voltage electric outlet.
- 2) Set up the Mini-Con Labeller and load the labels into the Labeller per the instructions in Sections 3 & 4 of this manual.
- 3) Plug the Labeller into the proper voltage electric outlet using the enclosed electric power cord which will go into the IEC connection located on the rear of the Touch Panel Controller.
- 4) Turn the Power On by using the rocker switch located on the front of the Touch Panel Controller. If the Conveyor does not begin to move, locate the Emergency Shut Off Button on the front of the Conveyor and pull it out.
- 5) Complete the set up described in Section #5 of this manual to utilize the options desired and to make sure that label placement is where needed. If this is not correct, refer to Section #5 of this manual and make the necessary changes.
- 6) Place a test product to be labeled onto the Conveyor and it should move forward and pass underneath the Main Label Head where a label should be dispensed onto the product and the product should continue to the end of the Conveyor. If the placement of the label is not correct, review Section #5 of this manual and make the necessary changes to the Start Delay and Motor Speed of the labeller and retry until proper placement is achieved. If the label is dispensed in the proper place, but not wiped down, use an allen screw and adjust the brush located to the right of the dispensing plate. This brush should have light contact with the top of the package as it moves along the conveyor. If the labels do not feed properly check Section #4 of this manual and confirm that the labels are properly loaded and that the Urethane Wiper or the Urethane over the dispensing plate is not causing too much tension to the label. If the label is not dispensing, tension made need to be added to the Urethane Wiper or the Urethane above the dispensing plate. If the labels continue to run and more than 1 label is fed, see Section #7 on the following page for instructions on adjusting the sensitivity of the Stop Sensor.

SECTION #6 OPERATION OF THE TACH-IT MINI-CON LABELER CONTINUED:

- 7) If any adjustments need to be made to the labeller, make the necessary adjustments.
- 8) The labeller is now ready for use.

SECTION #7 ADJUSTMENT TO THE SENSITIVITY OF THE STOP SENSOR (A-3):



The Stop Sensor (A-3) used on this machine is designed to read the gap (die cut) between the labels. If the labels continue to run, it may be necessary to change the sensitivity of the Stop Sensor. Instructions for this are as follows:

The LED signal strength indicator (yellow) lights continuously when there is optimum light reception. If it does not light, too little light is received: Increase the sensitivity using the “+” key.

Checking object detection:

Place object in light beam; the LED signal strength indicator (yellow) must switch off. If it remains lit, reduce the sensitivity on the “-” key until it switches off. The LED signal strength indicator (yellow) must light again after the object has been removed. If this is not the case, correct the sensitivity using the “+” key until the switching threshold is set correctly.

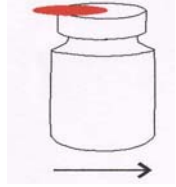
SECTION #8 TROUBLE SHOOTING:

PROBLEM	REMEDY
 <p>Label is positioned more to the front of the package than desired.</p>	<p>Adjust the label position by using the Start Delay. See Section #5 an example is as follows:</p> <div style="text-align: center;"> <div style="border: 1px solid black; padding: 5px; display: inline-block;">10</div> → <div style="border: 1px solid black; padding: 5px; display: inline-block;">20</div> </div>
 <p>Label is positioned more to the back of the package than desired.</p>	<p>Adjust the label position by using the Start Delay. See Section #5 an example is as follows:</p> <div style="text-align: center;"> <div style="border: 1px solid black; padding: 5px; display: inline-block;">30</div> → <div style="border: 1px solid black; padding: 5px; display: inline-block;">20</div> </div>
 <p>Label is positioned properly, but it is folded.</p>	<p>Labeller Motor Speed is faster than the conveyor speed. Adjust the labeller speed down. See Section #5 and as an example see the following.</p> <div style="text-align: center;"> <div style="border: 1px solid black; padding: 5px; display: inline-block;">1600</div> → <div style="border: 1px solid black; padding: 5px; display: inline-block;">1500</div> </div>
<p>The Label is not consistently placed onto the product.</p>	<ol style="list-style-type: none"> 1) Make sure that the Black Handle between the Pressing Rollers is in the closed position. See Section #4. 2) Check that both the Urethane Wiper and the Urethane above the Dispensing Plate are not causing too much tension on the label or are not too loose where the label is not separating properly. 3) The Stop Sensor is not adjusted properly. See Section #4

SECTION #8 TROUBLE SHOOTING CONTINUED:

PROBLEM	REMEDY
Labels are not feeding or dispensing.	Check the loading of the labels. See Section #4.
The labels continue to feed after the package has past the Start Sensor (A-7)	The Stop Sensor (A-3) may need to be adjusted. See Section #7.
The Touch Panel Controller turns Red	1) There is an error in the system. Follow the instructions in the manual to check everything and then try again. 2) The Target Counter has reached the desired number of packages to be labeled.
The label is not securely placed onto the package	Adjust the height of the brush that is to the right side of the dispensing plate.
The package is not traveling consistently on the Conveyor or is being stopped along it's path of travel.	Adjust the Product Rails—See Section #3 and / or adjust the height of the brush that is to the right side of the dispensing plate.

SECTION #9 PARTS LIST:

Parts No.	Main head parts
A-1-1	Label hanger inside
A-1-2	Label hanger outside
A-2	Stepping motor
A-3	Stop sensor
A-4	Width adjuster
A-5	Height adjuster
A-6	Dispensing plate
A-7	Start sensor
A-8-1	Press roller
A-8-2	Press knurling roller
A-9	Rewinder
A-10	Tension roller

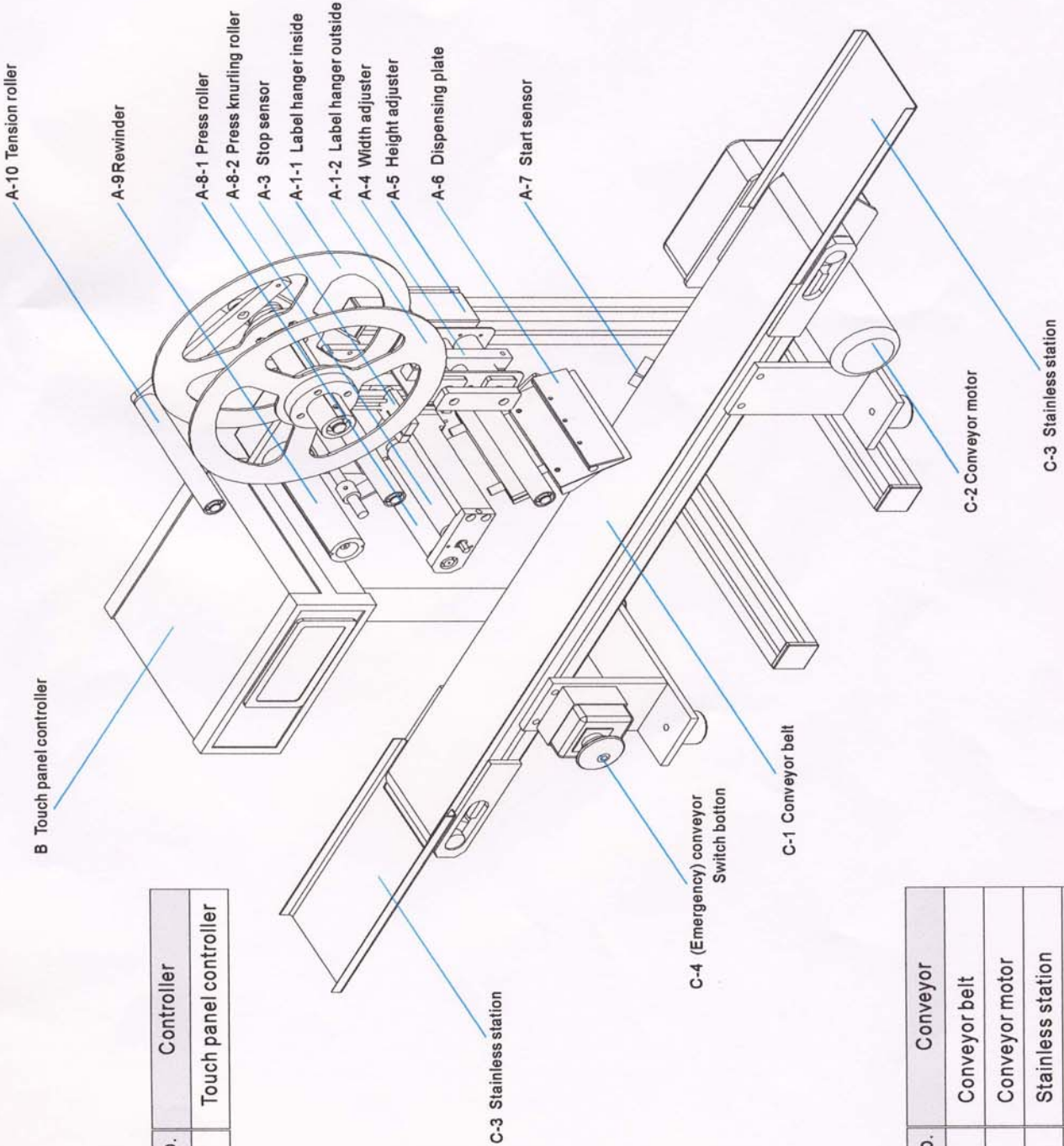

Parts No.	Controller
B	Touch panel controller

Parts No.	Conveyor
C-1	Conveyor belt
C-2	Conveyor motor
C-3	Stainless station
C-4	(Emergency) conveyor switch button